



Silicon Solutions Integrating Communications Worldwide

communicator

summer 1995

From the President

This issue of *communicator* is the first following a successful initial public offering of shares of TranSwitch Corporation's common stock.

The Company turned in a strong second quarter, posting revenue growth of 25 percent over the first quarter, 1995, and 46 percent ahead of second quarter, 1994. The first six months of '95 showed revenues up 30 percent over the same period last year as documented in a recently released Second Quarter '95 report. We are pleased that all financial results are meeting the trend line we expected.

In addition to continuing revenue growth and achieving the largest revenue quarter in the Company's history, an initial public offering of shares of common stock in June raised \$24

continued on page 2

L3M: DS3/E3 Multipurpose Mapper Introduced

The key to success of the newer fiber-based synchronous networks is their ability to seamlessly integrate with the existing asynchronous or Plesiochronous Digital Hierarchy (PDH) carrier systems. Although the specifications for Synchronous Optical Network (SONET) and Synchronous Digital Hierarchy (SDH) systems have always provided for carrying these asynchronous transmission channels, the process involves several complex steps to assure that the channels are faithfully replicated at the distant end.

This mapping process includes converting framing and control information to the new format, managing the combination of several different types of channels onto the same SONET/SDH link, dynamically handling the differences in speed between the two systems and providing for several different ways of interconnecting them to achieve reliable operation under all fault conditions.

Up to now, equipment vendors have had to design

special circuit implementations to handle all these issues, particularly with the higher speed systems such as DS3 and E3. Several years ago, TranSwitch introduced mappers that eased the problem of converting DS1 and E1 lines to proper SONET/SDH format. Based on the success of these devices, we embarked on the development of solutions for higher rate lines. As a result, TranSwitch now offers a single device that handles all of these mapping functions for both E3 and DS3 lines, fully implementing all the interface standards set for SONET/SDH. The Level 3 Mapper (L3M) combines the capability of mapping both DS3 and E3 to either SONET (North America) or SDH (Europe and the rest of the world) on a single chip. Additionally, a design has recently been completed for a mapping solution for E4 which will be announced shortly.

Applications for the L3M include:

continued on page 2

In this issue

TranSwitch Goes Public

IPO very successful

Victory at Sea

TranSwitch sponsors Special Olympics event

Product list

From the President...continued

million. This financing will provide the resources to sustain the Company's growth and maintain its position as a leader in its served markets.

Significant strides have been made in our technology development efforts during the last six months. We enhanced the performance of our ATM segmentation and reassembly devices (SARA products) which, we believe, have been adopted as the de facto industry standard. The Company also introduced the industry's first 4-channel DS-1 Framer device and completed the initial design phase of CUBIT™, a fully integrated ATM switching device and COBRA™, an ATM Adaptation Layer-1 processor for voice and data applications. The CUBIT and COBRA devices are now undergoing certification tests.

In summary, we have made excellent progress in product development, financial management and market penetration during the last six months. All indications from our customers support our conclusion that the adoption of SONET/SDH and ATM standards is accelerating throughout the world. It is apparent that TranSwitch is well-positioned and is gaining momentum as a leader in these evolving markets.

We look to the future with optimism and a firm commitment to serve our customers with the most advanced telecommunications and datacommunications VLSI solutions which accelerate their time-to-market and enable them to deliver systems that best meet the needs of their end-users.

DON'T MISS
Next Generation
Networks
November 6-9
Washington, D.C.

TranSwitch Goes Public

On June 14, TranSwitch Corporation announced an initial public offering of 2,500,000 shares of its Common Stock at the price of \$9 per share for trading on the NASDAQ National Market (TXCC).

The offering was managed by Robertson, Stephens & Company, L.P. and Hambrecht & Quist, L.L.C. Net proceeds of the offering will be used for general corporate purposes, including working capital, purchases of capital equipment and repayment of indebtedness.

Since June 14, stock activity has been brisk with the stock trading in the \$10-\$11 and over range.

A prospectus relating to the securities may be obtained from Robertson, Stephens & Company at 415-781-9700 or from Hambrecht & Quist, 415-576-3300.

L3M Mapper...continued

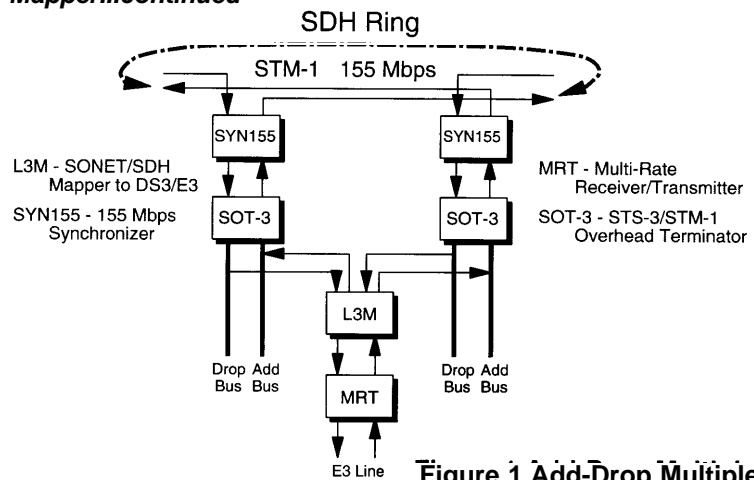

Figure 1 Add-Drop Multiplexor

Terminal Multiplexors — which combine up to three DS3s or E3s onto a 155 Mbps STS-3/STM-1 channel. The function will also work at high synchronous rates such as 622 Mbps.

Add-Drop Multiplexors — which allow one or more DS3 or E3 lines to be extracted from a SONET/SDH line that continues to another location, again adding and dropping more lines. This capability is particularly useful in the fiberoptic ring structures planned by many communications carriers. Figure 1 shows how L3M is used in a typical application for the European market. A similar structure would be used in North America for DS3 lines.

Digital CrossConnects — where multiple DS3 and/or E3 lines are reconfigured onto appropriate

SONET/SDH links to meet the changing needs of the communication carriers.

Test Equipment — where the Telecom Bus compliant aspects of the L3M allows its use in conjunction with mappers for other speeds to permit multipurpose testing with minimal components.

The L3M is a unique device, giving telecom system designers the flexibility of mapping DS3 (44.736 Mbps) or E3 (34.368 Mbps) signals to a synchronous carrier (e.g. 155 Mbps STS-3 or STM-1) with a single device.

L3M is compliant with both North American and ITU standards, has low power dissipation and an operating temperature range that meets a variety of operating environments. Built-in testing

continued on Page 3

3M Mapper...continued

features simplify system design of hardware, software and maintenance functions.

The many functions incorporated into the L3M to simplify system design and applications represent a breakthrough in multipurpose asynchronous signal mapping design.

The architecture of the L3M is different from other commercial or user-specific solutions and gives the user the ability to design products which can operate in many environments.

Standards require that an E3 signal be mapped through a TUG-3, AU-4 path and a DS3 signal to be mapped through a VC-3, AU-3 path. In addition to supporting these mapping formats, the L3M also provides for standards compliant crossmapping of a North American

DS3 via a TUG-3, AU-4 path into a European STM-1.

The L3M can be configured to support bus speeds of 19.44 Mhz or 6.48 Mhz. This selectable bus speed feature allows designers to implement systems for different hierarchies such as add drop multiplexer for STS-1 networks up to STM-4/STS-16 speeds.

Figure 2 shows the primary elements of this device. Note that each direction of transmission functions independently. This figure also shows that TranSwitch has kept the maintenance and administration needs of the system designers in mind in addition to supporting and complying with multiple standards and architectural demands.

The L3M features a built-in signal generator which can be selected to transmit a pseudo random test

sequence to the transmission channel. This signal generator can create pseudo random sequences of $2^{15}-1$ or $2^{23}-1$. Also, the L3M features a complementary signal analyzer which will detect the pseudo random sequence transmitted by another generator and reports on the integrity of those signals transmitted through the channels under test. Both the generator and the analyzer can be used independently.

This unique feature simplifies the implementation of maintenance and diagnostic functions. An additional benefit is the ability to support built-in self test functions in the production of cards which incorporate the L3M.

TranSwitch's engineers have kept in mind ease of manufacturability in designing this part. The L3M fully supports standard compliant boundary scan functionality.

continued on page 4

Figure 2 TranSwitch L3M Block Level Diagram

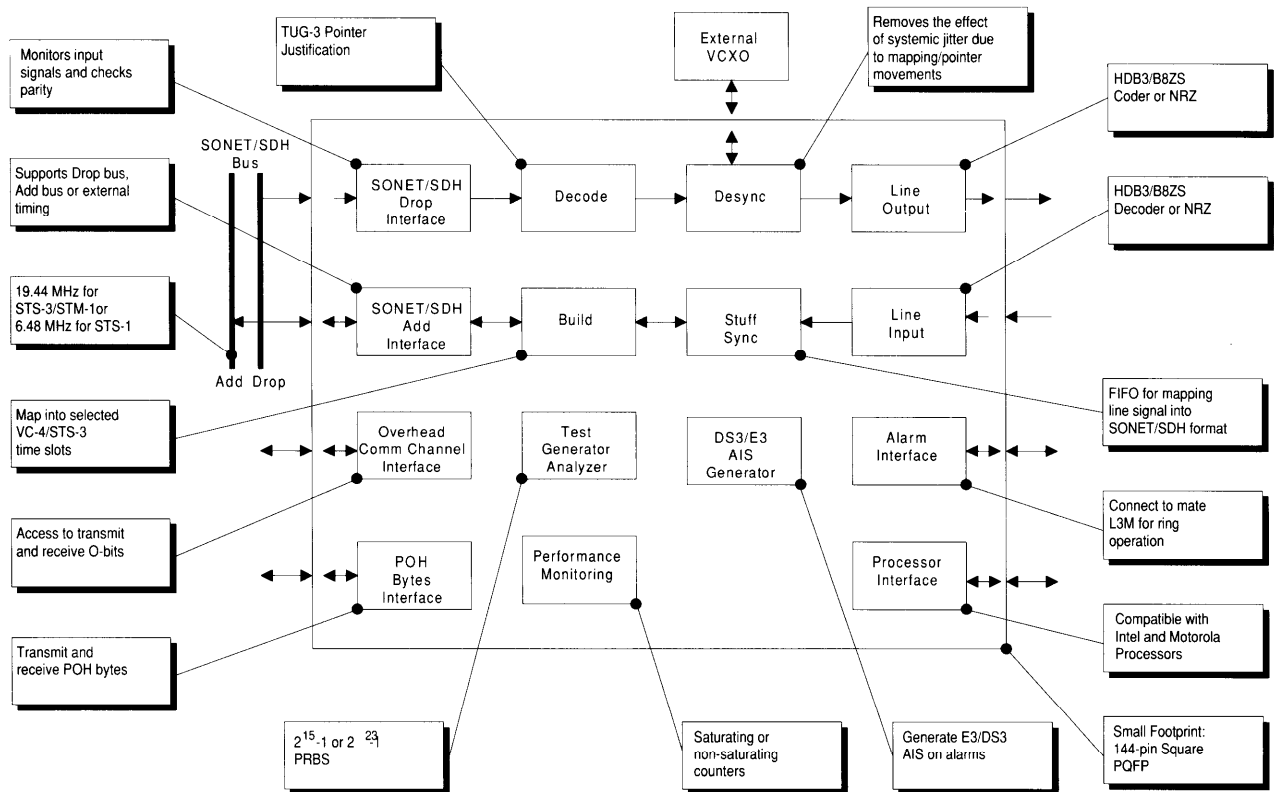

L3M Mapper... continued

For further maintenance flexibility, facility loopback is provided by a connection of signals from the input of the E3/DS3 line to the output of the E3/DS3 line. In this case, the input signals are still mapped into the SONET/SDH line. Alternatively, the line loopback connects the demapped signal from the SONET/SDH line back to be remapped into the SONET/SDH line as well as delivered to the E3/DS3 line. Finally, for SONET applications, the add bus signal can be looped back as the drop bus signal.

The L3M is packaged in a 144-pin 28 millimeter by 28 millimeter PQFP, and requires only 1 watt of +5V power. The L3M has an operating temperature range of -40°C to +85°C.

Two versions of the L3M are presently being produced. The TXC-0345 AIPQ without the cross mapping functionality is available and is shipping to customers in production quantities. TXC-0345 BIPQ with added cross mapping support is sampling now.

Extensive conformance and certification tests have been carried out on the L3M. In addition, extensive field experience has resulted from close collaboration with customers who participated in the early phase.

The Level 3 Mapper is a result of TranSwitch's long experience with high speed communications component design and thorough understanding of the applications environment for optical systems. It provides users with a very rapid method to implement new systems that conform to the latest standards while maintaining existing interfaces to previously designed asynchronous systems.

Santana Day



In the photo from left to right: Rob Dietz, Special Olympian David Ciaccio, and TranSwitch's Bob Dietz.

TranSwitch Part of Victory Sail

With wind in their sails and glory in their eyes, Special Olympic athletes gave it their all at the 1995 World Games held in New Haven, CT, July 1st through the 9th. TranSwitch was proud to be involved in this world class event by sponsoring a Hobie 18 for the sailing competition.

Nearly 7200 athletes participated in 19 different events, and some 120 athletes from seven countries competed in the two-person Hobie 18 and four-person Flying Scott courses on Long Island Sound.

TranSwitch's Purchasing Manager Bob Dietz and his son Rob donated a Hobie 18 for use in the games. Rob spent much of last summer training athletes who had never sailed before. He was a volunteer sailing safety officer during the competition.

Opening day was very exciting and colorful. Twenty-eight fully rigged Hobie 18s lined the beach at water's edge and twenty-four Flying Scotts, also fully rigged, lined the dock.

At the TranSwitch boat, spectators were greeted by David Ciaccio, an athlete from Toms River, NJ, sailing for team NJ. David is an accomplished sailor and the Olympic games was his third international regatta.

After a thorough equipment check, the boats pushed off one by one and headed out to the race site. The wind was good and the sky was clear. Spectators on the shore watched with binoculars and applauded as boats rounded the "mark."

By the end of the last day of competition, David had accumulated a score sufficient to earn a Gold Medal. As he stood on the podium with his arms raised and his Gold Medal around his neck, he repeated over and over "We did it!"

TranSwitch was indeed proud of David and proud to be part of this international, history-making event.

List of TranSwitch Products

<u>Product Name</u>	<u>Product Number</u>	<u>Product Description</u>
VLSI Devices		
ADMA-E1	TXC-04002	2 Mbit/s to TU-12 Async Mapper-Desync Device
ADMA-T1	TXC-04001	DS1 to VT-1.5 Async Mapper-Desync Device
ALI-25	TXC-07025	ATM Line interface Chipset, 25-Mbit/s
ART/ARTE	TXC-02020/21	Advanced DS3/STS-1 Line Interface Device
CDB	TXC-05150	ATM Cell Delineation Block Device
CDR	TXC-02624	SONET/SDH Clock and Data Recovery Device
COBRA	TXC-05427	Constant Bit Rate ATM Adaptation Layer 1 Device
CUBIT	TXC-05801	<i>CellBus</i> Interface Device
DJB	TXC-03351	Quad DS1 Dejitter Buffer Device
DS3F	TXC-03401	DS3 Framer Device
E2/E3F	TXC-03701	8-34-Mbit/s Framer Device
HDLC	TXC-05101	HDLC Controller, 36-bit Terminal I/O Device
JT2F	TXC-03702	6-Mbit/s Framer Device
L3M	TXC-03452	SDH/SONET Level 3 Mapper Device
L4M	TXC-03456	SDH/SONET Level 4 Mapper Device
M12	TXC-03375	DS2/DS1 Mux/Demux Device
M13/M13E	TXC-03301/03	DS3/DS1 MUX/DEMUX Device
MRT	TXC-02050	6-8-34-Mbit/s Line Interface Device
QDS1F	TXC-03102	Quad DS1 Framer Device
QT1M	TXC-04251	Quad T1 Mapper
SARA-R	TXC-05601	ATM/SMDS Reassembly Controller Device
SARA-S	TXC-05501	ATM/SMDS Segmentation Controller Device
SM3	TXC-02201	SONET STS-3/STS-1 Mux/Demux Device
SOT-1	TXC-03001	SONET STS-1 Overhead Terminator Device
SOT-3	TXC-03003	STM-1/STS-3/STS-3c Overhead Terminator Device
STAF	TXC-02623	SONET/SDH Transceiver and Framer Device
SYN155C	TXC-02302	155-Mbit/s Synchronizer Device, Clock and Data Output
XBERT	TXC-06125	Bit Error Rate Generator/Receiver Device
Modules		
DS3LIM	TXC-20049/153	DS3 Line Interface Module
Evaluation Boards		
ATM-EB	TXC-21103	ATM EISA Evaluation Board
DS3F-EB	TXC-21005	DS3 Framer Evaluation Board
DS3LIM-EB	TXC-21049	DS3 Line Interface Module Evaluation Board
E2/E3F-EB	TXC-21037	E2/E3 Framer Evaluation Board
HDLC-EB	TXC-21043	HDLC Evaluation Board
HDLC/HSSI-EB	TXC-21095	HDLC/High Speed Serial Interface (HSSI) Evaluation Board
HSSI DTE	TXC-21087	HSSI DTE Emulation Board
JT2-EB	TXC-21047	JT2 Framer Evaluation Board
MRT-EB	TXC-21055	MRT Evaluation Board
SOT-3/SYN155-EB	TXC-21061	SOT-3/SYN155/ADMA-E1 Evaluation Board
XBERT-EB	TXC-21075	XBERT Bit Error Rate Generator/Receiver Evaluation Board
Development Support Systems		
SONGEN-51E/155F	TXC-21007	Signal Generator-Analyzer: STS-1 Electrical and STM-1/STS-3/STS-3c Fiber Optic Interfaces
SONGEN-155E/155F	TXC-21107	Signal Generator-Analyzer: STM-1/STS-3/STS-3c Electrical
SONGEN-PBI	TXC-20047	SONGEN Processor Board: Parity and Pointer Processor

communicator © 1995 is a publication of **TranSwitch Corporation**. If you have comments, suggestions, need more copies, or wish to reprint any portion of this newsletter, contact Mary Koch, TranSwitch Corporation, 8 Progress Drive, Shelton, CT 06484 USA. Phone: (203) 929-8810 Fax: (203) 926-9453 e-mail: mary@txc.com
